

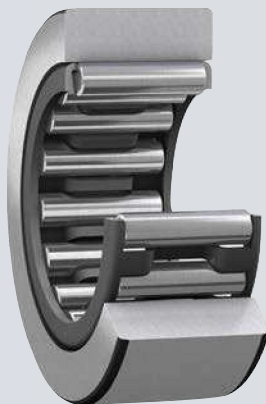

15

Support rollers



# 15 Support rollers



<b>Designs and variants</b> .....	<b>945</b>
Support rollers without flange rings .....	945
(R)STO design support rollers .....	945
(R)NA 22...2RS design support rollers .....	945
Support rollers with flange rings .....	946
NATR and NATV design support rollers .....	946
NUTR .. A design support rollers .....	946
PWTR ...2RS design support rollers .....	946
NNTR ...2ZL design support rollers .....	947
Cages .....	947
<b>Lubrication</b> .....	<b>947</b>
Relubrication requirements .....	947
Relubrication features .....	947
<b>Bearing data</b> .....	<b>948</b>
(Dimension standards, profile of the outer ring running surface, tolerances, internal clearance, defect frequencies)	
<b>Loads</b> .....	<b>949</b>
(Dynamic loads, static loads, axial loads, minimum load, equivalent dynamic bearing load, equivalent static bearing load)	
<b>Temperature limits</b> .....	<b>950</b>
<b>Speed limits</b> .....	<b>950</b>
<b>Design considerations</b> .....	<b>950</b>
Pins .....	950
Support surfaces .....	951
Axial gap .....	951
<b>Mounting</b> .....	<b>951</b>
<b>Designation system</b> .....	<b>952</b>
<b>Product tables</b>	
<b>15.1</b> Support rollers without flange rings, with an inner ring .....	954
<b>15.2</b> Support rollers with flange rings, with an inner ring .....	956

# 15 Support rollers

## More information

<b>General bearing knowledge . . . . .</b>	<b>17</b>
<b>Bearing selection process . . . . .</b>	<b>59</b>
Lubrication . . . . .	109
Bearing interfaces. . . . .	139
Sealing, mounting and dismounting . . . . .	193

SKF support rollers (yoke-type track rollers based on roller bearings) are designed to run on all types of tracks and to be used in cam drives, conveyor systems, etc.

SKF support rollers are based on needle or cylindrical roller bearings.

SKF supplies them ready-to-mount. To meet the requirements of different applications, they are available in several designs and variants (**fig. 1**):

- with or without a cage
- with or without flange rings
- with or without an inner ring
- with or without seals (sealed or open)
- with the outer ring running surface profile:
  - crowned as standard
  - cylindrical (flat)

## Support roller features

- **Accommodate high radial loads**  
The thick-walled outer ring enables high radial loads, while reducing distortion and bending stresses.
- **Long service life**  
The crowned outer ring running surface is beneficial for applications where outer ring tilting relative to the track may occur or where edge stresses need to be minimized.

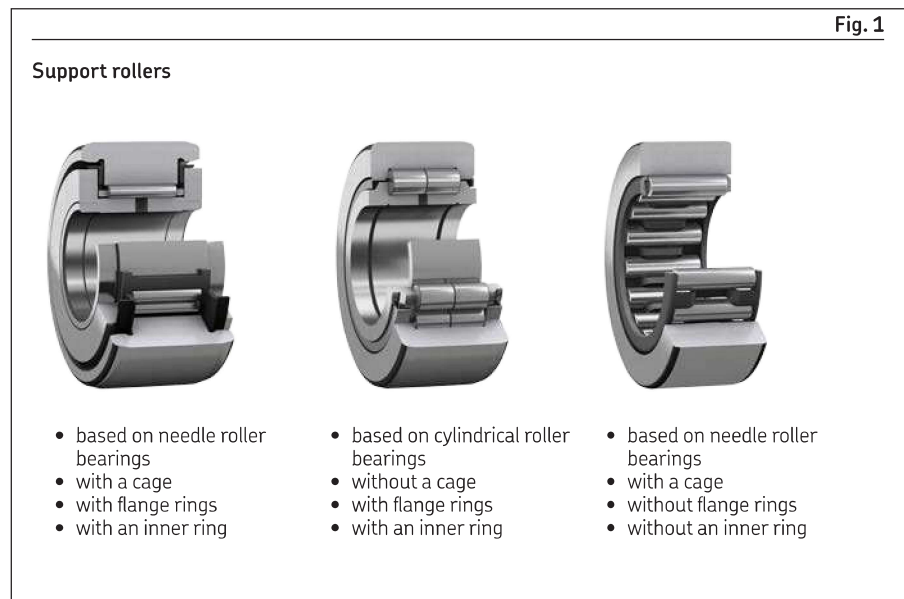

# Designs and variants

SKF support rollers are available without or with flange rings (fig. 2). They have a thick-walled outer ring with its running surface crowned as standard. However, support rollers with a cylindrical (flat) running surface are also available (designation suffix X).

Support rollers without flange rings require adjacent components to guide the outer ring and cage axially.

Support rollers with flange rings do not need adjacent components to guide the outer ring and cage axially (fig. 3). Axial loads, which are induced when shafts are not horizontal or aligned properly, are accommodated by the flange rings.

## Support rollers without flange rings

- require adjacent components to guide the outer ring and cage axially
  - are based on needle roller bearings
  - are available:
    - with an inner ring, which is slightly wider than the outer ring to avoid axial clamping of the outer ring
    - without an inner ring (designation prefix R), intended for arrangements where the pin or shaft is hardened and ground
- These support rollers are not listed in this catalogue, but can be found online at [skf.com/go/17000-15-3](http://skf.com/go/17000-15-3).

## (R)STO design support rollers

- are available (fig. 4):
  - with an inner ring that can be mounted separately from the outer ring and roller and cage assembly, which must always be kept together as supplied
  - without an inner ring (prefix R)
  - only open (without seals)

## (R)NA 22...2RS design support rollers

- are available (fig. 5):
  - with an inner ring that can be mounted separately from the outer ring and roller and cage assembly
  - without an inner ring (prefix R)
  - greased and capped with a sheet steel reinforced NBR contact seal on both sides
- have the needle roller and cage assembly axially guided between two integral flanges in the outer ring to form a non-separable unit

Fig. 2

### Support rollers

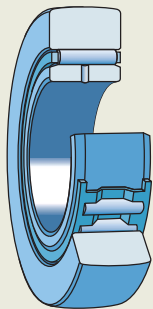

without flange rings

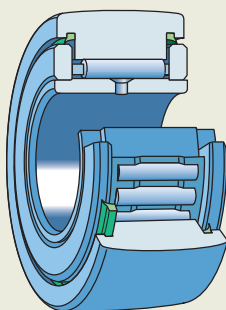

with flange rings

Fig. 3

### Application of support roller with flange rings

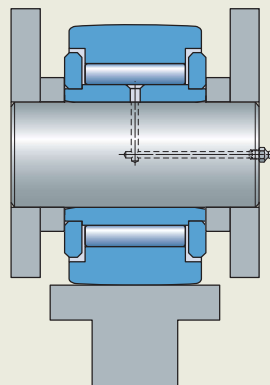
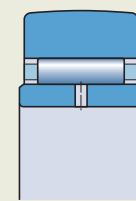
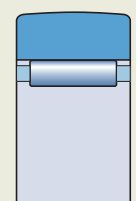

Fig. 4



STO



RSTO

Fig. 5

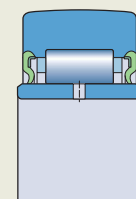

NA 22...2RS

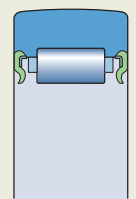

RNA 22...2RS



## Support rollers with flange rings

15  

- do not need adjacent components to guide the outer ring and cage axially (fig. 3, page 945)
- are non-separable units
- have different flange designs:
  - pressed-on flange rings (NATR and NATV designs)
  - loose flange rings (NUTR, PWTR and NNTR designs)
- accommodate axial loads that can occur because of skew or tilting

### NATR and NATV design support rollers

- are based on (fig. 6):
  - a needle roller and cage assembly (NATR design)
  - a full complement of needle rollers (NATV design)
- have the outer ring axially guided by pressed-on flange rings, forming a gap-type seal

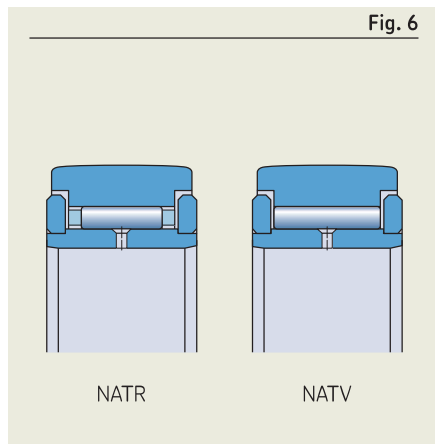

- are also available with an axial sliding ring on both sides (designation suffixes PPA, fig. 7, and PPXA):
  - made of PA66
  - forming narrow labyrinth seals with the outer ring in a radial direction, to protect against coarse contaminants
  - serving as contact seals in an axial direction to retain grease reliably in the bearing
  - improving lubrication conditions in the bearing, keeping friction and frictional heat low, and extending grease life

### NUTR .. A design support rollers

- are based on double row full complement cylindrical roller bearings without an integral flange between the two roller sets (fig. 8)
- have an outer ring with two integral flanges, which guide the roller sets axially
- have an inner ring with two loose flange rings, which guide the outer ring axially via the roller sets
- have a sheet metal angle ring pressed into the outer ring shoulder on both sides:
  - forming an effective labyrinth seal
  - extending over the flange rings, making the bearing non-separable
- accommodate relatively heavy axial loads that can occur because of skew or tilting
- can be supplied with a reinforced (thicker) outer ring to accommodate heavy peak loads (e.g. NUTR 50 A → NUTR 50110 A)

### PWTR ...2RS design support rollers

- are based on double row full complement cylindrical roller bearings (fig. 9)
- have an outer ring with three integral flanges, which guide the roller sets axially
- have an inner ring with two loose flange rings, which guide the outer ring axially via the roller sets
- have a relatively large grease quantity between the two roller sets
- are fitted on both sides with an NBR contact seal, being integral with a sheet metal angle ring that is pressed into the outer ring shoulder:
  - to press against the flange rings
  - extending over the flange rings, making the bearing non-separable
- accommodate relatively heavy axial loads that can occur because of skew or tilting
- can be supplied with a reinforced (thicker) outer ring to accommodate heavy peak loads (e.g. PWTR 50.2RS → PWTR 50110.2RS)

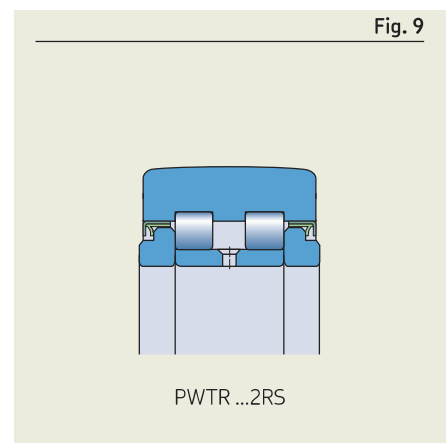
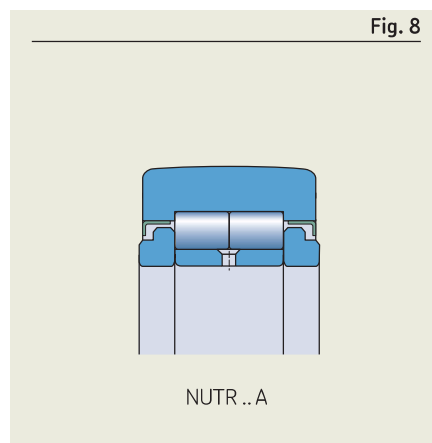
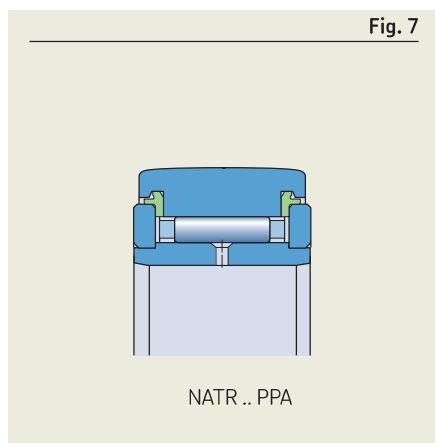

## NNTR ...2ZL design support rollers

- are based on double row full complement cylindrical roller bearings (fig. 10)
- have an outer ring with three integral flanges, which guide the roller sets axially
- have an inner ring with two loose flange rings, which guide the outer ring axially via the roller sets
- have a relatively large grease quantity between the two roller sets
- are fitted with a lamellar seal on both sides, inserted into recesses in the shoulders of the flange rings and the outer ring, making the bearing non-separable
- accommodate very heavy radial loads and relatively heavy axial loads that can occur because of skew or tilting

## Cages

SKF support rollers, if not a full complement of rollers, are fitted with one of the cages shown in table 1. The standard cage is not identified in the bearing designation.

When used at high temperatures, some lubricants can have a detrimental effect on polyamide cages. For additional information about the suitability of cages, refer to *Cages*, page 187.

## Lubrication

SKF support rollers are supplied greased (table 1, page 933).

(R)STO design support rollers can be oil or grease lubricated. In applications where oil is used, SKF recommends thoroughly washing the initial grease fill from the bearing prior to operation.

For general information, refer to *Lubrication*, page 109.

## Relubrication requirements

Support rollers:

- should be relubricated regularly to achieve their full service life, even if the initial grease fill still has its full lubricating properties
- used in applications where there are light loads, relatively low speeds and clean surroundings can operate for long periods before relubrication is required

- that operate under contaminated and damp conditions at high speeds or at temperatures > 70 °C (160 °F) require more frequent relubrication
- without a cage (full complement of rollers) require more frequent relubrication

## Relubrication features

The inner rings of SKF support rollers have one lubrication hole, except:

- NNTR designs with  $d \leq 90$  mm → three lubrication holes
- NNTR designs with  $d \geq 100$  mm → six lubrication holes

If suitable ducts are provided in the pin, the bearings are easy to relubricate.

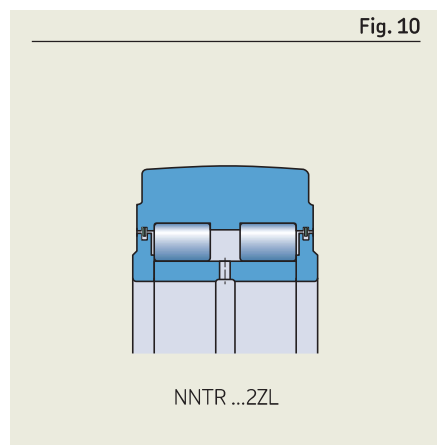

<b>Cage type</b>	Window-type, centring depends on size and design	Window-type, outer raceway centred
<b>Material</b>	Sheet steel	PA66, glass fibre reinforced
<b>Suffix</b>	–	TN



# Bearing data

<b>Dimension standards</b>	<ul style="list-style-type: none"> <li>• <b>(R)NA 22 designs</b> ISO 15, dimension series 22, except for the outer ring width</li> <li>• <b>NATR, NATV, NUTR .. A, PWTR designs</b> ISO 7063 and ANSI/ABMA Standard 18.1 (where standardized)</li> <li>• <b>(R)STO designs</b> Not standardized</li> </ul>
<b>Profile of the outer ring running surface</b>	<ul style="list-style-type: none"> <li>• <b>(R)STO, (R)NA 22, NATR, NATV designs</b> Radius = 500 mm</li> <li>• <b>NNTR design</b> D ≤ 260 mm → Radius = 10 000 mm D ≥ 290 mm → Radius = 15 000 mm</li> <li>• <b>NATR .. PPA, NATV .. PPA, NUTR .. A, PWTR designs</b> Improved crowned profile for better load distribution, higher stiffness and reduced wear</li> </ul>
<b>Tolerances</b>  For additional information → <a href="#">page 35</a>	Normal, except: <ul style="list-style-type: none"> <li>• diameter of the crowned running surface:             <ul style="list-style-type: none"> <li>– NNTR design → h10</li> <li>– other designs → 0/–0,05 mm</li> </ul> </li> <li>• width B:             <ul style="list-style-type: none"> <li>– NNTR design → 0/–0,5 mm</li> <li>– NATR, NATV, NUTR .. A, PWTR designs → h12</li> </ul> </li> <li>• inside diameter <math>F_w</math>:             <ul style="list-style-type: none"> <li>– RSTO, RNA 22 designs → F6</li> </ul> </li> </ul> Values for Normal tolerance class: ISO 492 ( <a href="#">table 2, page 38</a> ) Values for ISO tolerance classes: h10, h12 and F6 ( <a href="#">table 2, page 950</a> )
<b>Internal clearance</b>  For additional information → <a href="#">page 182</a>	<ul style="list-style-type: none"> <li>• <b>STO and NA 22 designs</b> Normal</li> <li>• <b>Other designs</b> Between C2 and Normal</li> </ul> Values: ISO 5753-1 ( <a href="#">table 11, page 603</a> ) Values are valid for unmounted bearings under zero measuring load.
<b>Defect frequencies</b>	→ <a href="https://skf.com/bearingcalculator">skf.com/bearingcalculator</a>

# Loads

<b>Dynamic loads</b>	<p>As track rollers are not supported in a housing, the outer rings deform, leading to an altered load distribution and bending stresses in the outer ring.</p> <p>The basic load ratings listed in the <a href="#">product tables, page 954</a>, take into account the altered load distribution, while the maximum radial loads <math>F_{r\max}</math> (<a href="#">product tables</a>) are based on the bending stresses.</p>	<b>Symbols</b>  $C_0$ basic static load rating [kN] ( <a href="#">product tables, page 954</a> ) $F_r$ radial load [kN] $F_{r\max}$ maximum permissible dynamic radial load [kN] ( <a href="#">product tables</a> ) $F_{0r\max}$ maximum permissible static radial load [kN] ( <a href="#">product tables</a> ) $F_{rm}$ minimum radial load [kN] $P$ equivalent dynamic bearing load [kN] $P_0$ equivalent static bearing load [kN]
<b>Static loads</b>	<p>Permissible static load is the lower value of <math>F_{0r\max}</math> or <math>C_0</math> (<a href="#">product tables</a>).</p> <p>Where requirements for smooth running are below normal, the static load may exceed <math>C_0</math>, but should never exceed the maximum permissible static radial load <math>F_{0r\max}</math>.</p>	
<b>Axial loads</b>	<p>Support rollers are intended for radial loads. However, support rollers with flange rings can generally accommodate axial loads that can occur because of skew or tilting. The magnitude of permissible load depends on the internal design.</p>	
<b>Minimum load</b>  For additional information → <a href="#">page 106</a>	$F_{rm} = 0,0167 C_0$	
<b>Equivalent dynamic bearing load</b>  For additional information → <a href="#">page 91</a>	$P = F_r$	
<b>Equivalent static bearing load</b>  For additional information → <a href="#">page 105</a>	$P_0 = F_r$	



# Temperature limits



The permissible operating temperature for support rollers can be limited by:

- the dimensional stability of the bearing rings and rollers
- the cage
- the seals
- the lubricant

Where temperatures outside the permissible range are expected, contact SKF.

## Bearing rings and rollers

SKF support rollers are heat stabilized up to at least 140 °C (280 °F).

## Cages

Steel cages can be used at the same operating temperatures as the bearing rings and rollers. For temperature limits of PA66 cages, refer to *Polymer cages*, [page 188](#).

## Seals

The permissible operating temperature for seals depends on the seal material:

- NBR: -40 to +100 °C (-40 to +210 °F)  
Temperatures up to 120 °C (250 °F) can be tolerated for brief periods.
- PA66 sliding rings: -30 to +100 °C (-20 to +210 °F)

Typically, temperature peaks are at the seal lip.

## Lubricants

Temperature limits for greases used in SKF support rollers are provided in [table 1](#), [page 947](#). For temperature limits of other SKF greases, refer to *Selecting a suitable SKF grease*, [page 116](#).

When using lubricants not supplied by SKF, temperature limits should be evaluated according to the SKF traffic light concept ([page 117](#)).

# Speed limits

The limiting speed listed in the [product tables](#) is a mechanical limit that should not be exceeded unless the bearing design and the application are adapted for higher speeds.

For additional information, refer to *Operating temperature and speed*, [page 130](#).

# Design considerations

## Pins

For general information, refer to *Bearing interfaces*, [page 139](#).

For support rollers with an inner ring, the pin/shaft should be machined to tolerance class g6Ⓜ under the following conditions:

- stationary inner ring load
- where easy displacement of the inner ring is required

Table 2

### ISO tolerance classes

Nominal dimension		h7Ⓜ Deviations		h9Ⓜ Deviations		h10Ⓜ Deviations		h12Ⓜ Deviations		F6Ⓜ Deviations	
>	≤	U	L	U	L	U	L	U	L	U	L
mm		μm		μm		μm		μm		μm	
3	6	0	-12	-	-	-	-	-	-	-	-
6	10	0	-15	0	-36	-	-	-	-	+22	+13
10	18	0	-18	0	-43	-	-	0	-180	+27	+16
18	30	0	-21	0	-52	-	-	0	-210	+33	+20
30	50	-	-	0	-62	-	-	0	-250	+41	+25
50	80	-	-	-	-	-	-	-	-	+49	+30
120	180	-	-	-	-	0	-160	-	-	-	-
180	250	-	-	-	-	0	-185	-	-	-	-
250	315	-	-	-	-	0	-210	-	-	-	-

To exploit the full load carrying capacity of support rollers without an inner ring, the pin/shaft should:

- be machined to tolerance class k5<sup>Ⓔ</sup>
- be machined to a surface finish similar to a bearing raceway
- have the same hardness as a bearing raceway

For additional information about raceways on shafts, refer to *Raceways on shafts and in housings*, page 179.

## Support surfaces

For support rollers without flange rings, the outer ring support surfaces:

- guide the outer ring and cage during operation
- must be fine turned
- must be free of burrs and clean
- should extend to at least half the outer ring side face (fig. 11), if unhardened – hardened surfaces may be smaller

Heavily loaded support rollers with flange rings should be axially supported:

- over the entire flange ring side faces (fig. 12)
- according to diameter  $d_1$  (product table, page 956)

## Axial gap

The following support rollers must be located without any axial gap:

- support rollers without flange rings, with an inner ring (fig. 11)
- support rollers with flange rings (fig. 12)

Support rollers without an inner ring must have an axial gap  $\geq 0,2$  mm between the outer ring and the support surfaces (fig. 13).

## Mounting

SKF recommends positioning the lubrication hole in the unloaded zone of the inner ring. Positioning is not needed for PWTR and NNTR design support rollers, which have the lubrication holes in the empty space between the two roller sets.

Where mounting the outer ring assembly and inner ring separately, care must be taken not to damage the seal lips.



Fig. 11

Support roller without flange rings – guiding surface design

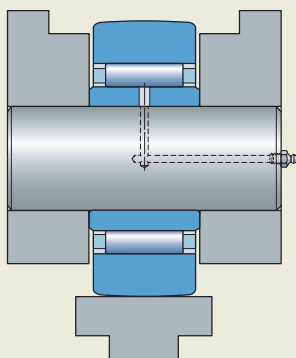

Fig. 12

Support roller with flange rings – support surface design

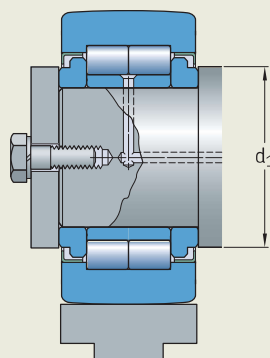
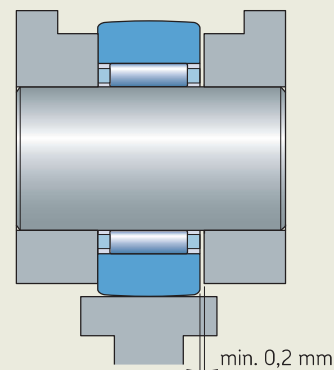

Fig. 13

Support roller without an inner ring – axial gap



# Designation system



**Prefixes**

**R** Support roller without an inner ring

**Basic designation**

- NA 22** Support roller without a flange ring, fitted with a needle roller and cage assembly
- STO** Support roller without a flange ring, fitted with a needle roller and cage assembly
- NATR** Support roller with two pressed-on flange rings, fitted with a needle roller and cage assembly
- NATV** Support roller with two pressed-on flange rings, fitted with a full complement of needle rollers
- NUTR** Support roller based on a double row full complement cylindrical roller bearing with two integral outer ring flanges and a loose flange ring on both sides of the inner ring
- NNTR** Support roller based on a double row full complement cylindrical roller bearing with three integral outer ring flanges and a loose flange ring on both sides of the inner ring
- PWTR** Support roller based on a double row full complement cylindrical roller bearing with three integral outer ring flanges and a loose flange ring on both sides of the inner ring

**Suffixes**

**Group 1: Internal design**

**Group 2: External design (seals, snap ring groove, etc.)**

- .2RS** NBR contact seal on both sides
- .2ZL** Lamellar seal on both sides
- A** Improved crowned profile of the outer ring running surface (NUTR design)
- PPA** PA66 axial sliding and sealing ring on both sides. Improved crowned profile of the outer ring running surface
- PPXA** PA66 axial sliding and sealing ring on both sides. Cylindrical (flat) profile of the outer ring running surface
- X** Cylindrical (flat) profile of the outer ring running surface

**Group 3: Cage design**

**TN** Glass fibre reinforced PA66 cage

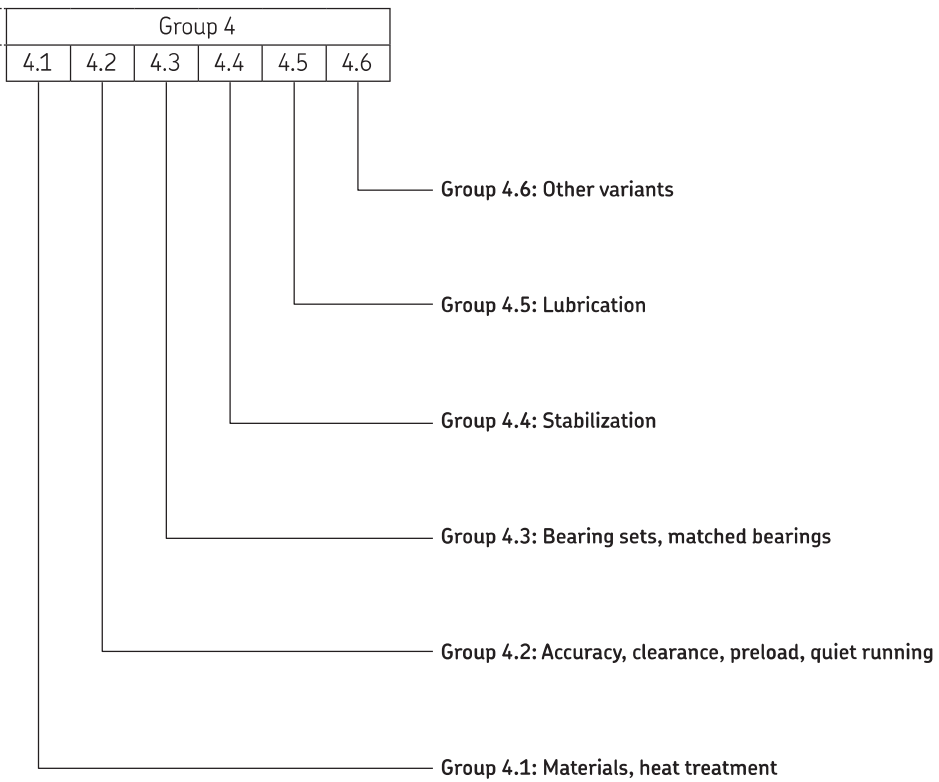

## 15.1 Support rollers without flange rings, with an inner ring

D 19 – 90 mm

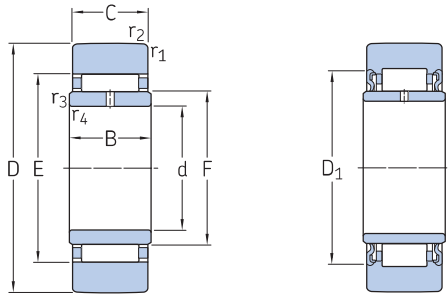

STO

NA 22...2RS

Principal dimensions				Basic load ratings		Fatigue load limit	Maximum radial loads		Limiting speed	Mass	Designation
D	d	C	B	C	C <sub>0</sub>		F <sub>r</sub> max.	F <sub>0r</sub> max.			
mm				kN		kN	kN		r/min	kg	–
19	6	9,8	10	3,74	4,5	0,5	4,25	6,1	7 000	0,017	▶ STO 6 TN NA 22/6.2RS
	6	11,8	12	4,02	3,65	0,425	2,55	3,6	7 000	0,022	
24	8	9,8	10	4,13	5,4	0,6	7,5	10,8	7 000	0,026	STO 8 TN ▶ NA 22/8.2RS
	8	11,8	12	4,68	4,55	0,54	5,3	7,5	6 700	0,034	
30	10	11,8	12	8,25	8,8	1,04	8,5	12,2	6 000	0,049	▶ STO 10 ▶ NA 2200.2RS
	10	13,8	14	6,6	7,5	0,88	12	17,3	6 300	0,06	
32	12	11,8	12	8,8	9,8	1,18	8,3	12	5 600	0,057	▶ STO 12 ▶ NA 2201.2RS
	12	13,8	14	7,04	8,5	1	11,6	16,6	6 000	0,067	
35	15	11,8	12	9,13	10,6	1,27	7,1	10	5 000	0,063	STO 15 ▶ NA 2202.2RS
	15	13,8	14	7,48	9,3	1,12	9,5	13,7	5 000	0,075	
40	17	15,8	16	9,52	13,2	1,6	15,3	22	4 500	0,11	▶ NA 2203.2RS STO 17
	17	15,8	16	14,2	17,6	2,08	12	17,3	4 500	0,11	
47	20	15,8	16	16,1	21,2	2,5	18,6	26,5	4 000	0,15	STO 20 ▶ NA 2204.2RS
	20	17,8	18	16,1	18	2,16	17,6	25,5	4 000	0,18	
52	25	15,8	16	16,5	22,8	2,7	18	26	3 400	0,18	STO 25 ▶ NA 2205.2RS
	25	17,8	18	16,8	20	2,4	17,3	24,5	3 400	0,21	
62	30	19,8	20	17,9	25,5	3,05	28,5	40,5	2 800	0,32	NA 2206.2RS STO 30
	30	19,8	20	22,9	34,5	4,25	23,6	33,5	2 600	0,31	
72	35	19,8	20	24,6	39	4,8	36	51	2 200	0,44	STO 35 NA 2207.2RS
	35	22,7	23	22,4	35,5	4,3	38	54	2 200	0,51	
80	40	19,8	20	23,8	39	4,75	34,5	49	1 900	0,53	STO 40 ▶ NA 2208.2RS
	40	22,7	23	27,5	40,5	5	35,5	51	1 900	0,63	
90	50	22,7	23	28,1	43	5,3	34,5	50	1 600	0,69	NA 2210.2RS

▶ Popular item



---

**Dimensions**

D	D <sub>1</sub>	E	F	r <sub>1,2</sub> min.	r <sub>3,4</sub> min.
---	----------------	---	---	--------------------------	--------------------------

---

 mm
 

---

19	–	13	10	0,3	0,3
	16	–	10	0,3	0,3
24	–	15	12	0,3	0,3
	18	–	12	0,3	0,3
30	–	20	14	0,3	0,3
	20	–	14	0,6	0,3
32	–	22	16	0,3	0,3
	22	–	16	0,6	0,3
35	–	26	20	0,3	0,3
	26	–	20	0,6	0,3
40	28	–	22	1	0,3
	–	29	22	0,3	0,3
47	–	32	25	0,3	0,3
	33	–	25	1	0,3
52	–	37	30	0,3	0,3
	38	–	30	1	0,3
62	43	–	35	1	0,3
	–	46	38	0,6	0,6
72	–	50	42	0,6	0,6
	50	–	42	1,1	0,6
80	–	58	50	1	1
	57	–	48	1,1	0,6
90	68	–	58	1,1	0,6

## 15.2 Support rollers with flange rings, with an inner ring

D 16 – 40 mm

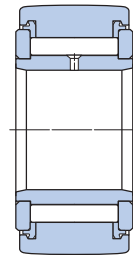
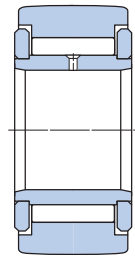
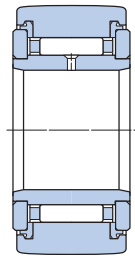
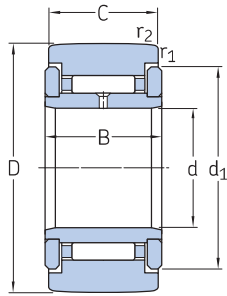

NATR

NATR.. PPA

NATV

NATV.. PPA

Principal dimensions				Basic load ratings		Fatigue load limit	Maximum radial loads		Limiting speed	Mass	Designation
D	d	C	B	C	C <sub>0</sub>	P <sub>u</sub>	F <sub>r</sub> max.	F <sub>0r</sub> max.			
mm	mm	mm	mm	mm	mm	kN	kN	kN	r/min	kg	–
16	5	11	12	3,14	3,2	0,345	2,9	4,15	6 000	0,014	NATR 5
	5	11	12	3,14	3,2	0,345	2,9	4,15	6 000	0,014	▶ NATR 5 PPA
	5	11	12	4,73	6,55	0,72	4,05	5,7	4 300	0,015	▶ NATR 5
	5	11	12	4,73	6,55	0,72	4,05	5,7	4 300	0,015	▶ NATV 5 PPA
19	6	11	12	3,47	3,8	0,415	3,8	5,5	5 600	0,02	▶ NATR 6
	6	11	12	3,47	3,8	0,415	3,8	5,5	5 600	0,019	▶ NATR 6 PPA
	6	11	12	5,28	8	0,88	5,1	7,35	4 000	0,021	NATV 6
	6	11	12	5,28	8	0,88	5,1	7,35	4 000	0,021	▶ NATV 6 PPA
24	8	14	15	5,28	6,1	0,695	5,2	7,35	5 000	0,038	▶ NATR 8 PPA
	8	14	15	7,48	11,4	1,32	7,35	10,4	3 600	0,042	NATV 8
	8	14	15	7,48	11,4	1,32	7,35	10,4	3 600	0,041	▶ NATV 8 PPA
30	10	14	15	6,44	8	0,88	7,8	11,2	4 800	0,064	▶ NATR 10
	10	14	15	6,44	8	0,88	7,8	11,2	4 800	0,061	▶ NATR 10 PPA
	10	14	15	8,97	14,6	1,66	11	15,6	3 200	0,065	NATV 10
	10	14	15	8,97	14,6	1,66	11	15,6	3 200	0,064	▶ NATV 10 PPA
32	12	14	15	6,6	8,5	0,95	7,65	10,8	4 500	0,071	NATR 12
	12	14	15	6,6	8,5	0,95	7,65	10,8	4 500	0,066	▶ NATR 12 PPA
	12	14	15	9,35	15,3	1,76	10,6	15	3 000	0,072	▶ NATV 12
	12	14	15	9,35	15,3	1,76	10,6	15	3 000	0,069	▶ NATV 12 PPA
35	15	18	19	9,52	13,7	1,56	11,4	16,3	4 000	0,1	▶ NATR 15
	15	18	19	9,52	13,7	1,56	11,4	16,3	4 000	0,095	▶ NATR 15 PPA
	15	18	19	12,3	23,2	2,7	14,6	20,8	2 600	0,11	NATV 15
	15	18	19	12,3	23,2	2,7	14,6	20,8	2 600	0,1	▶ NATV 15 PPA
40	17	20	21	10,5	14,6	1,73	12,5	18	3 400	0,14	▶ NATR 17
	17	20	21	10,5	14,6	1,73	12,5	18	3 400	0,14	▶ NATR 17 PPA
	17	20	21	14,2	26,5	3,1	17	24,5	2 200	0,15	NATV 17
	17	20	21	14,2	26,5	3,1	17	24,5	2 200	0,15	▶ NATV 17 PPA
	17	20	21	19	22	2,5	14	20	4 500	0,15	▶ NUTR 17 A
	17	20	21	13,8	14,3	1,5	13,7	19,6	4 500	0,15	▶ PWTR 17.2RS

▶ Popular item

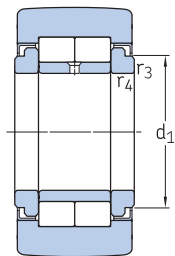

NUTR..A

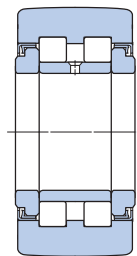

PWTR...2RS

### Dimensions

D	d <sub>1</sub>	r <sub>1,2</sub> min.	r <sub>3,4</sub> min.
mm			
16	12,5	0,15	–
	12,5	0,15	–
	12,5	0,15	–
	12,5	0,15	–
19	15	0,15	–
	15	0,15	–
	15	0,15	–
24	15	0,15	–
	19	0,3	–
	19	0,3	–
	19	0,3	–
30	23	0,6	–
	23	0,6	–
	23	0,6	–
	23	0,6	–
32	25	0,6	–
	25	0,6	–
	25	0,6	–
	25	0,6	–
35	27,6	0,6	–
	27,6	0,6	–
	27,6	0,6	–
	27,6	0,6	–
	20	0,6	0,3
	20	0,6	0,3
40	31,5	1	–
	31,5	1	–
	31,5	1	–
	31,5	1	–
	22	1	0,5
	22	1	0,5

## 15.2 Support rollers with flange rings, with an inner ring

D 42 – 72 mm

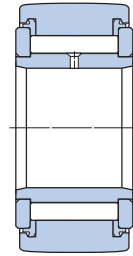
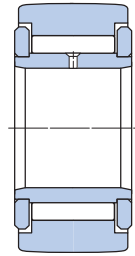
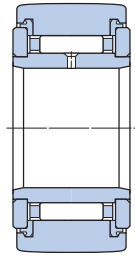
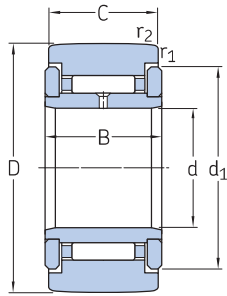

NATR

NATR..PPA

NATV

NATV..PPA

Principal dimensions				Basic load ratings		Fatigue load limit	Maximum radial loads		Limiting speed	Mass	Designation
D	d	C	B	C	C <sub>0</sub>	P <sub>u</sub>	F <sub>r</sub> max.	F <sub>0r</sub> max.			
mm	mm	mm	mm	mm	mm	kN	kN	kN	r/min	kg	–
42	15	18	19	20,1	23,2	2,65	21,6	31	5 000	0,16	▶ NUTR 1542 A PWTR 1542.2RS
	15	18	19	14,2	15	1,6	22	31,5	5 000	0,16	
47	17	20	21	22	27	3,05	30	43	4 500	0,22	▶ NUTR 1747 A PWTR 1747.2RS ▶ NATR 20
	17	20	21	15,7	17,6	1,86	30	42,5	4 500	0,22	
	20	24	25	14,7	24,5	2,9	23,6	33,5	3 000	0,25	
47	20	24	25	14,7	24,5	2,9	23,6	33,5	3 000	0,24	▶ NATR 20 PPA NATV 20 ▶ NATV 20 PPA
	20	24	25	19,4	41,5	5	30,5	43	1 900	0,25	
	20	24	25	19,4	41,5	5	30,5	43	1 900	0,25	
	20	24	25	28,6	33,5	3,9	17,6	25	3 800	0,25	
47	20	24	25	22,9	24,5	2,8	18,3	26	3 800	0,25	▶ NUTR 20 A PWTR 20.2RS
	20	24	25	22,9	24,5	2,8	18,3	26	3 800	0,25	
52	20	24	25	31,9	39	4,55	30	42,5	3 800	0,32	▶ NUTR 2052 A PWTR 2052.2RS ▶ NATR 25
	20	24	25	25,5	29	3,35	30,5	44	3 800	0,32	
	25	24	25	14,7	25,5	3,1	21,6	31	2 400	0,28	
52	25	24	25	14,7	25,5	3,1	21,6	31	2 400	0,27	▶ NATR 25 PPA NATV 25 ▶ NATV 25 PPA
	25	24	25	19,8	44	5,3	28,5	40,5	1 600	0,29	
	25	24	25	19,8	44	5,3	28,5	40,5	1 600	0,28	
52	25	24	25	29,7	36	4,25	18	25,5	3 200	0,28	▶ NUTR 25 A PWTR 25.2RS
	25	24	25	23,8	26,5	3,05	18,6	26,5	3 200	0,28	
62	25	24	25	35,8	48	5,6	44	63	3 200	0,45	▶ NUTR 2562 A PWTR 2562.2RS ▶ NATR 30
	25	24	25	29,2	36	4,05	45	64	3 200	0,45	
	30	28	29	22,9	37,5	4,55	26,5	38	1 800	0,47	
62	30	28	29	22,9	37,5	4,55	26,5	38	1 800	0,44	▶ NATR 30 PPA NATV 30 ▶ NATV 30 PPA
	30	28	29	29,2	62	7,65	34,5	49	1 400	0,48	
	30	28	29	29,2	62	7,65	34,5	49	1 400	0,47	
62	30	28	29	41,3	47,5	5,85	24	34,5	2 600	0,47	▶ NUTR 30 A PWTR 30.2RS
	30	28	29	31,9	32,5	4,05	20,4	29	2 600	0,47	
72	30	28	29	48,4	61	7,5	53	76,5	2 600	0,7	▶ NUTR 3072 A PWTR 3072.2RS ▶ NATR 35 PPA
	30	28	29	39,6	45	5,6	47,5	68	2 000	0,7	
	35	28	29	24,6	43	5,3	33,5	48	1 600	0,55	
72	35	28	29	31,9	72	8,8	43	62	1 100	0,63	▶ NATV 35 PPA NUTR 35 A PWTR 35.2RS
	35	28	29	45,7	57	6,95	33,5	47,5	2 000	0,63	
	35	28	29	35,8	40,5	5	28	40	2 000	0,63	

▶ Popular item

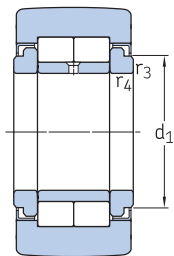

NUTR..A

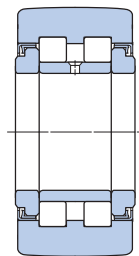

PWTR...2RS

## Dimensions

D	d <sub>1</sub>	r <sub>1,2</sub> min.	r <sub>3,4</sub> min.
---	----------------	--------------------------	--------------------------

mm

42	20	0,6	0,3
	20	0,6	0,3
47	22	1	0,5
	22	1	0,5
	36,5	1	–
	36,5	1	–
	36,5	1	–
	36,5	1	–
52	27	1	0,5
	27	1	0,5
52	41,5	1	–
	41,5	1	–
	41,5	1	–
	31	1	0,5
	31	1	0,5
	31	1	–
62	51	1	–
	51	1	–
	51	1	–
	38	1	0,5
	38	1	0,5
	38	1	–
72	58	1,1	–
	58	1,1	–
	44	1,1	0,6
	44	1,1	0,6
	44	1,1	0,6
	44	1,1	0,6